

EVD-2

ELECTRONIC VIBRATION DETECTOR SYSTEM

INSTALLATION, OPERATION AND INSTRUCTION MANUAL

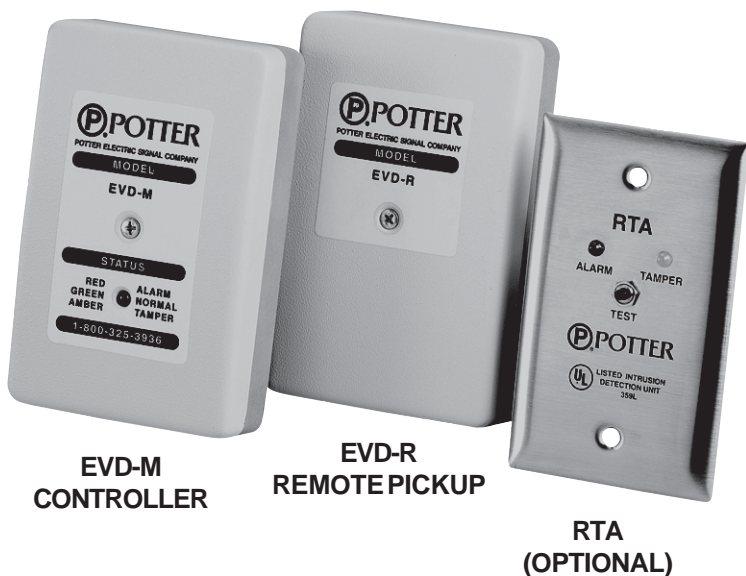

**EVD-M
CONTROLLER**

**EVD-R
REMOTE PICKUP**

**RTA
(OPTIONAL)**



POTTER ELECTRIC SIGNAL COMPANY
2081 CRAIG ROAD • P.O. BOX 28480 • ST. LOUIS, MO 63146-4161
(800) 325-3936 • (314) 878-4321 • FAX: (314) 878-7264
www.pottersignal.com
Manual #5401042 • Rev L • 5/03

ALL SPECIFICATIONS SUBJECT TO REVISION



WARRANTY INFORMATION

The essential purpose of any sale or contract for sale of any of the products listed in the POTTER catalog or price list is the furnishing of that product. It is expressly understood that in furnishing said product, POTTER does not agree to insure the Purchaser against any losses the Purchaser may incur, even if resulting from the malfunction of said product.

POTTER warrants that the equipment herein shall conform to said descriptions as to all affirmations of fact and shall be free from defects of manufacture, labeling and packaging for a period of one (1) year* from the invoice date to the original purchaser, provided that representative samples are returned to POTTER for inspection. Upon a determination by POTTER that a product is not as warranted, POTTER shall, at its exclusive option, replace or repair said defective product or parts thereof at its own expense except that Purchaser shall pay all shipping, insurance and similar charges incurred in connection with the replacement of the defective product or parts thereof. This Warranty is void in the case of abuse, misuse, abnormal usage, faulty installation or repair by unauthorized persons, or if for any other reason POTTER determines that said product is not operating properly as a result of causes other than defective manufacture, labeling or packaging.

THE AFORESAID WARRANTY IS EXPRESSLY MADE IN LIEU OF ANY OTHER WARRANTIES, EXPRESSED OR IMPLIED, IT BEING UNDERSTOOD THAT ALL SUCH OTHER WARRANTIES, EXPRESSED OR IMPLIED, INCLUDING THE WARRANTIES OF MERCHANTABILITY AND FITNESS FOR PARTICULAR PURPOSE ARE HEREBY EXPRESSLY EXCLUDED. IN NO EVENT SHALL POTTER BE LIABLE TO PURCHASER FOR ANY DIRECT, COLLATERAL, INCIDENTAL OR CONSEQUENTIAL DAMAGES IN CONNECTION WITH PURCHASER'S USE OF ANY OF THE PRODUCTS LISTED HEREIN, OR FOR ANY OTHER CAUSE WHATSOEVER RELATING TO THE SAID PRODUCTS. NEITHER POTTER NOR ITS REPRESENTATIVES SHALL BE LIABLE TO THE PURCHASER OR ANYONE ELSE FOR ANY LIABILITY, CLAIM, LOSS, DAMAGE OR EXPENSE OF ANY KIND, OR DIRECT COLLATERAL, INCIDENTAL OR CONSEQUENTIAL DAMAGES RELATIVE TO OR ARISING FROM OR CAUSED DIRECTLY OR INDIRECTLY BY SAID PRODUCTS OR THE USE THEREOF OR ANY DEFICIENCY, DEFECT OR INADEQUACY OF THE SAID PRODUCTS. IT IS EXPRESSLY AGREED THAT PURCHASER'S EXCLUSIVE REMEDY FOR ANY CAUSE OF ACTION RELATING TO THE PURCHASE AND/OR USE OF ANY OF THE PRODUCTS LISTED HEREIN FROM POTTER SHALL BE FOR DAMAGES, AND POTTER'S LIABILITY FOR ANY AND ALL LOSSES OR DAMAGES RESULTING FROM ANY CAUSE WHATSOEVER, INCLUDING NEGLIGENCE, OR OTHER FAULT, SHALL IN NO EVENT EXCEED THE PURCHASE PRICE OF THE PRODUCT IN RESPECT TO WHICH THE CLAIM IS MADE, OR AT THE ELECTION OF POTTER, THE RESTORATION OR REPLACEMENT OR REPAIR OF SUCH PRODUCT.

*All products identified by the symbol (E) carry the warranty for 5 years from invoice date.

Potter Electric Signal Company
2081 Craig Road • P.O. Box 28480 • St. Louis, MO 63146-4161
(314) 878-4321 • (800) 325-3936
www.pottersignal.com

Contents

GENERAL INFORMATION	5
FEATURES	5
SPECIFICATIONS	5
ORDERING INFORMATION	5
EVD-M CONTROLLER	6
ACCUMULATOR FUNCTION	6
EVD-M CONTROLLER DETAILS	7
EVD-M TERMINAL CONNECTIONS	7
EVD-R REMOTE PICKUP	8
END OF LINE RESISTOR LOCATIONS	8
EVD-R REMOTE PICKUP DETAILS	9
EVD-R TERMINAL CONNECTIONS	9
RECOMMENDED WIRING EVD-2 SYSTEM	10
RECOMMENDED WIRING	11
RECOMMENDED WIRE TYPES	11
RECOMMENDED CONTROL PANEL WIRING AND RTA CONNECTIONS	12
INSTALLATION	12
EVD WIRING WITH SAFE DETECTOR ZONE AND 24 HOUR ALARM ZONE	13
EVD WIRING WITH SAFE DETECTOR ZONE ONLY	14
SENSITIVITY ADJUSTMENTS	15
ANALOG TEST POINT LEVELS	15
TESTING	16
RECOMMENDED DETECTOR LOCATIONS	17
DETERMINING THE NUMBER OF DETECTORS FOR A SAFE APPLICATION	18
DETERMINING THE MAXIMUM LINEAR DISTANCE ON A SAFE	19
TYPICAL SAFE EXTERIOR DIMENSIONS AND MAXIMUM LINEAR DISTANCES	19
TYPICAL UL COMPLETE SAFE INSTALLATIONS	20
TYPICAL UL COMPLETE VAULT INSTALLATIONS	20
EVD-2 WALL PROTECTION	20
WALL PROTECTION DIAGRAM	20
RECOMMENDED MAXIMUM EVD-M/EVD-R SPACING	21
FOR WALL PROTECTION	21
DIMENSIONS	21
EVD-M OR EVD-R MOUNTING TEMPLATE	22

GENERAL INFORMATION

The EVD-2, Electronic Vibration Detector System, is listed by Underwriters Laboratories, Inc. and Underwriters Laboratories of Canada for primary protection of Mercantile or Bank, safe or vault and supplementary protection of interior units such as file cabinets, display cases, walls and ceilings. The System must be used with an appropriate UL listed control unit.

The standard EVD-2 system consists of a model EVD-M controller and a model EVD-R remote pickup.

FEATURES

- Detects all common threats to safes, vaults and ATM's.
- Sophisticated signal processing provides unprecedented sensitivity without false alarms.
- Expandable system allows up to 15 remote pickups, (Model EVD-R).
- Reliable, sensitive piezo sensor technology.
- On board high security safe contact interface.
- Integral, multi-color status LED.
- Built in test circuit on both controller and remote pickups.
- Remote test and annunciator capabilities.
- Supervised microprocessor.
- Independent tamper output.
- On board test point facilitates installation and service.
- Built in accumulator.

Specifications

Dimensions: (EVD-M and EVD-R)
5.10"H x 3.26"W x 1.20"D
(13,0cm H x 8,3cm W x 3,0cm D)

Weight: EVD-M 0.64 lbs. (0,29 kg)
EVD-R 0.62 lbs. (0,28 kg)

Enclosure: Base: Die-cast aluminum
Cover: Stamped Steel, 22 Gauge

Power Input: 9.0 VDC to 16.0 VDC, 12 VDC Nominal
Maximum 0.1 V ripple

Typical Current: (Supply Voltage 12.0 VDC)
Normal Standby Condition: 34 mA
Alarm Condition: 33 mA
Tamper Condition: 41 mA

Each additional EVD-R Remote Pickup adds approx. 3 mA
With model RTA connected, add 10 mA in Tamper Condition and 10 mA in Alarm condition

Maximum Current: (Supply Voltage 16.0 VDC)
Normal Standby Condition: 36 mA
Alarm Condition: 33 mA
Tamper Condition: 43 mA
With model RTA connected, add 14 mA in Tamper Condition and 14 mA in Alarm condition

Contact Data: Alarm Relay: Form C, 2.0 Amps at 30 VDC
Tamper Contact: Form A, 2.0 Amps at 30 VDC

Optional Accessories: RTA Remote Test Annunciator
UL Listed High Security Cable
Required for UL safe complete installations

ORDERING INFORMATION

Description	Stock No.
EVD-2 SYSTEM	2020300
CONSISTING OF:	
1 EVD-M Controller	2020250
1 EVD-R Remote Pickup	2020260
EVD-2C Safe/Vault Pak	2020240
Includes:	
1 HSC-1 High Security Door Contact	
OPTIONAL EQUIPMENT:	
RTA Remote Test Annunciator	2020270
High Security Cable ("B" Cable)	5210408

Note: If 12 VDC is not available from main burglar panel, the following power supply is recommended:

12 VDC Power Supply	2020310
16.5 VAC Transformer	2020320

WARNING: If the main burglar panel has ground fault detection circuitry, it may be necessary to power the EVD from a separate power supply, not from the auxiliary power on the burglar panel. Alternately, the safe may be insulated from ground.

EVD-M CONTROLLER

The EVD-M controller is a microprocessor controlled, vibration detector that incorporates advanced detection methods for identifying all common types of attacks. It detects short duration, large amplitude signals like those produced in attacks from explosions, hammering or chiseling. It also detects long duration, small amplitude signals like those produced in attacks from torches, thermic lances, drills, grinders or cutting discs. As soon as the EVD-M detects a large amplitude alarm source it signals an alarm. Small amplitude alarm sources must persist for 15 seconds before the EVD-M signals an alarm. Alarm contacts operate for a minimum of 2 seconds.

The EVD-M contains two sensitivity adjustments: one for EVD-M's internal pickup, another one for a network of remote pickups. The EVD-M controller supports up to 15 EVD-R remote pickups, (or may be used as a stand alone unit), and fully supervises EVD-R wiring. The EVD-M signals wiring faults as alarms. A cover tamper and a back tamper protect the EVD-M from cover removal or prying. If either tamper on the EVD-M activates or any remote pickup signals tamper, the EVD-M will signal a tamper alarm condition. Tamper alarm contacts operate for a minimum of 2 seconds. If more than five remote pickups signal a tamper condition, the EVD-M will signal an alarm. **The internal pickup of the EVD-M is always active, regardless of any tamper condition.**

The model EVD-M controller provides a Form C, alarm contact for connection into the alarm protective circuit. Additionally, the EVD-M provides an independent, Form A, tamper alarm contact which can be wired as a separate 24 hour alarm circuit or wired in series with the alarm protective circuit. The EVD-M includes accessory terminals for an alarm condition remote annunciator, a tamper alarm remote annunciator, and a remote test input. The remote test input terminal permits the connection of dry contacts from any Underwriters Laboratories listed central station test unit. The remote test annunciator, model RTA, provides a normally open test switch and alarm and tamper alarm annunciators that interface directly to the accessory terminals of the EVD-M.

In addition to its remote test capability, the EVD-M provides a magnetically activated test switch that permits testing of the installation. The EVD-M contains a multi-color LED to indicate system status. This status LED indicates several states:

EVD-M Status	Status LED Color	Alarm Contacts	Tamper Alarm Contacts
Normal	Green	Inactive	Inactive
Tamper	Amber (1)	Inactive	Active
Alarm	Red (2)	Active	Inactive or Active (1)
No Power	Off	Active	Active

NOTES:

1. If both an alarm condition and a tamper condition exist, the status LED will indicate RED for the alarm. The remote annunciators and the alarm and tamper alarm contacts will indicate both alarm and tamper alarm conditions.
2. If the microprocessor fails, the status LED will blink RED and both the alarm and tamper alarm contacts will be activated.

ACCUMULATOR FUNCTION

The EVD-M contains a rotary switch that controls the EVD-M's accumulator setting. This accumulator, when activated, accumulates impact events. When the number of valid signals matches the setting on the rotary switch, the EVD-M signals an alarm. This feature can be useful for installing an EVD-2 system where some noise is normal. The accumulator is only active when the rotary switch setting is NOT zero. The threshold for valid signals is controlled by the sensitivity settings for the internal pickup and the remote pickups. If EVD-M has not detected enough valid signals for an alarm and five minutes pass after the last valid signal, the EVD-M resets the accumulator count to zero. As an aid to installers, the EVD-M blinks its status LED for each valid accumulator signal that it detects. (This feature is only active while the EVD-M cover is off and if the accumulator is activated, i.e., during installation.) An analog test point provides signal level information to simplify installations.

Refer to Figure 1 for key component locations and terminal descriptions.

Figure 1.

EVD-M CONTROLLER DETAILS

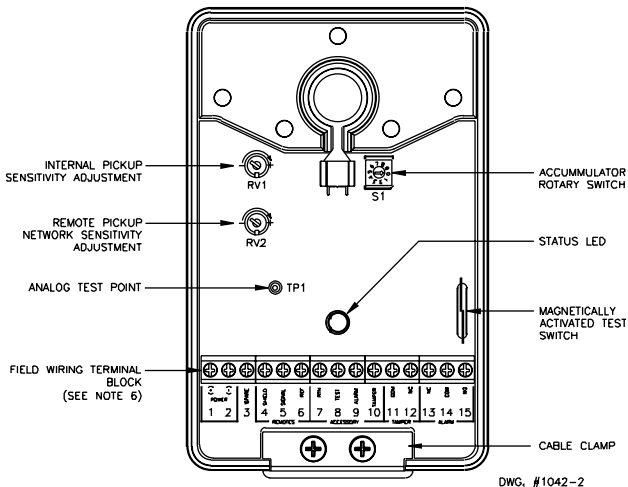

EVD-M TERMINAL CONNECTIONS

TERMINAL NO.	TERMINAL NAME	DESCRIPTION
1	(+)	Power Supply Connection, +12 VDC, nominal (See note 1)
2	(-)	Power Supply Connection, 0 VDC (See note 1)
3	SPARE	Spare Terminal Block Position
4	SHIELD	Remote Pickup Cable Shield Connection or End of Line Resistor (See note 2)
5	SIGNAL	Remote Pickup Sensor Signal or End of Line Resistor (See note 2)
6	REF	Remote Pickup Reference Signal or End of Line Resistor (See note 2)
7	RTN	Accessory Return Connection (See note 3)
8	TEST	Accessory Remote Test Input, Connect to RTN to Activate Test (See note 3)
9	ALARM	Accessory Remote Annunciator, Alarm (See notes 3, 4)
10	TAMPER	Accessory Remote Annunciator, Tamper (See notes 3, 5)
11	COM	Tamper Alarm Contact, Common
12	NC	Tamper Alarm Contact, Normally Closed in NON-TAMPER STATE
13	NC	Alarm Relay Contact, Normally Closed in NON-ALARM STATE
14	COM	Alarm Relay Contact, Common
15	NO	Alarm Relay Contact, Normally Open in NON-ALARM STATE

NOTES:

1. Observe polarity of power supply connections. **Application of voltages greater than 18 VDC may result in damage to unit.**
2. If EVD-R remote pickups are installed, remove the factory installed, 10K Ohm, 1% end of line resistors from pins 4-5 and pins 5-6. See Figures 2a and 4 for details.
3. Connections to optional RTA, Remote Test Annunciator, or dry contacts from any UL listed central station test unit. See Figure 5 for details.
4. Remote annunciator terminal provides power-limited +12 VDC when alarm contact is in its ALARM state. **Limit current draw to 10mA.**
5. Remote annunciator terminal provides power-limited +12 VDC when tamper alarm contact is in its TAMPER state. **Limit current draw to 10mA.**
6. Pins 1-15 are power limited.

EVD-R REMOTE PICKUP

The EVD-R remote pickup detects attack vibrations with the same vibration sensing components as the internal pickup on the EVD-M controller. The EVD-R amplifies and transmits these vibrations to the EVD-M controller.

A cover tamper and a back tamper protect the EVD-R from cover removal or prying. If either of these tampers activate or the tamper from the safe contact interface activates, the EVD-R will signal a tamper condition to the EVD-M. **During a tamper condition, the EVD-R network is fully capable of signaling alarm conditions to the EVD-M controller.** If more than five EVD-R remote pickups simultaneously signal tamper to the EVD-M controller, the EVD-M will signal an alarm.

The EVD-R contains a magnetically activated test switch that permits testing of each EVD-R in the remote pickup network. The EVD-R provides terminals for the connection of dry contacts from any Underwriters Laboratories listed safe contact.

Refer to Figure 3 for key component locations and terminal descriptions.

Figure 2. END OF LINE RESISTOR LOCATIONS

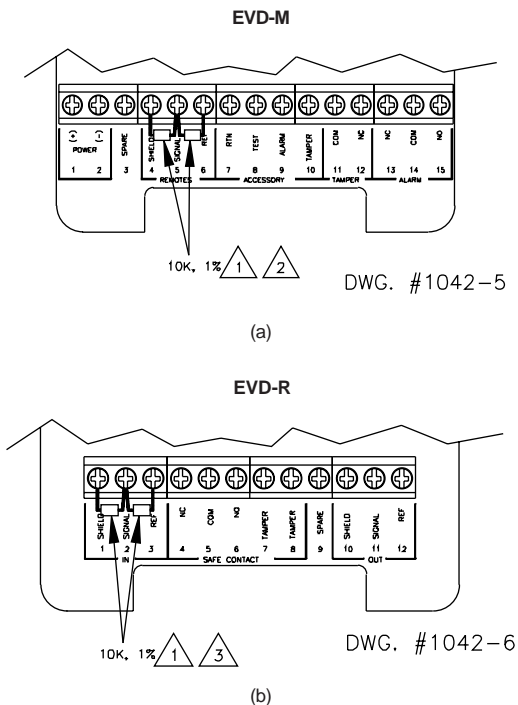

NOTES:

1. Be sure that end of line resistor leads do not make contact with other connections.
2. If any EVD-R remote pickups are connected, remove end of line resistors. (Refer to Figure 4.)
3. If the OUT terminals of another EVD-R are wired to the IN terminals of an EVD-R, remove the factory installed end of line resistors on the EVD-R. (Refer to Figure 4.)

Figure 3.

EVD-R REMOTE PICKUP DETAILS

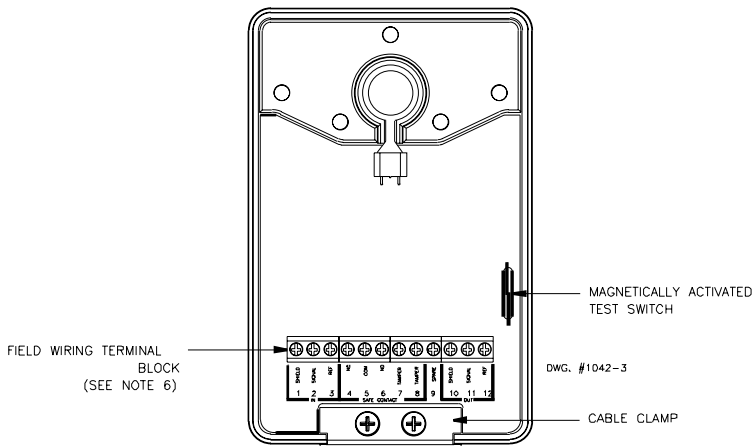

EVD-R TERMINAL CONNECTIONS

TERMINAL NO.	TERMINAL NAME	DESCRIPTION
1	SHIELD	Input Shield Connection from OUT SHIELD of Previous Pickup or End of Line Resistor (See note 1)
2	SIGNAL	Input Sensor Signal from OUT SIGNAL of Previous Pickup or End of Line Resistor (See note 1)
3	REF	Input Reference from OUT REF of Previous Pickup or End of Line Resistor (See note 1)
4	NC	Normally Closed Connection to Safe Contact (See notes 2,3)
5	COM	Common connection to Safe Contact (See notes 2,3)
6	NO	Normally Open Connection to Safe Contact (See notes 2,4)
7	TAMPER	Tamper Connection to Safe Contact (See notes 2,5)
8	TAMPER	Tamper Connection to Safe Contact (See notes 2,5)
9	SPARE	Spare Terminal Block Connection
10	SHIELD	Output Shield Connection to IN SHIELD of Next Pickup or EVD-M SHIELD Connection
11	SIGNAL	Output Sensor Signal to IN SIGNAL of Next Pickup or EVD-M SIGNAL Connection
12	REF	Output Reference to IN REF of Next Pickup or EVD-M REF Connection

NOTES:

1. Remove all factory installed 10K Ohm, 1% end of line resistors from pins 1-2 and pins 2-3 of all EVD-R's except the **LAST** EVD-R remote pickup in the remote pickup network. See Figures 2b and 4 for details.
2. Connections to optional dry contacts from any UL listed safe contact. See Figure 4 for details.
3. If a safe contact is connected, remove the factory installed jumper from pins 4-5. **Pins 4-5 must be NORMALLY CLOSED for the non-alarm state.**
4. **Pins 5-6 must be NORMALLY OPEN for the non-alarm state.**
5. If safe contact tamper is connected, remove the factory installed jumper from pins 7-8. **Pins 7-8 must be NORMALLY CLOSED for the non-tamper state.**
6. Pins 1-12 are power limited.

Figure 4.

RECOMMENDED WIRING EVD-2 SYSTEM

(Shown with 2 additional EVD-R remote pickups)

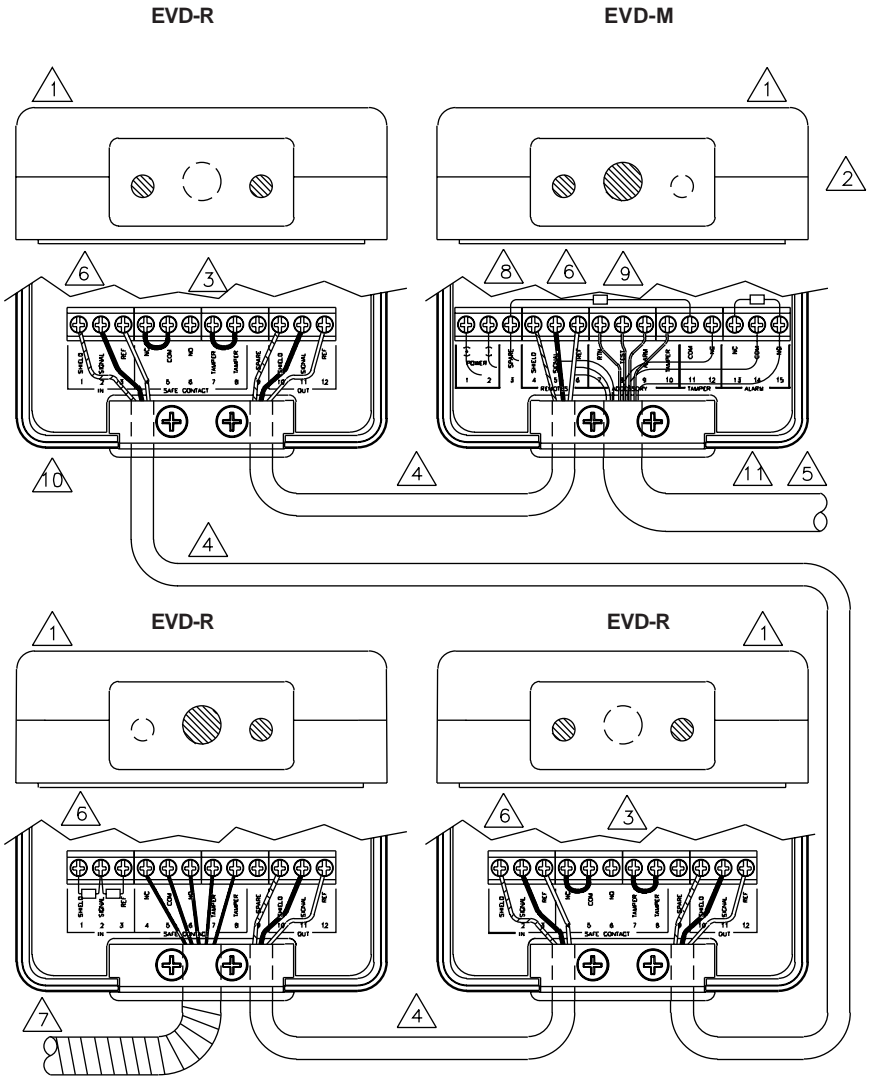

DWG. #1042-1B

RECOMMENDED WIRING

Figure 4 shows the recommended wiring for an EVD-2 system with two additional EVD-R remote pickups. **(All wiring should be as specified in Table 1 or with UL listed equivalents.)**

1. Cable clamp knockout locations are shaded. Be sure to remove clamp from base and to cleanly knock out cable openings in the cable clamp before feeding wire through the clamp.
2. Without a safe contact, the EVD-M requires the standard, factory installed, cable clamp, (Potter #5280104) for the configuration shown in Figure 4.
3. If a safe contact is not connected, the factory installed jumpers on pins 4-5 and pins 7-8 of the EVD-R must **not** be removed.
4. Wiring to or from remote pickups must be UL listed, shielded, twisted-pair cabling, (See Table 1). **The EVD-R remote pickup network wiring must not exceed 2000 feet.**
5. Connections to UL listed control unit via UL listed, high security cable, or alternates (See Table 1). See Figure 5b & 5c for 4 or 6 wire installation wiring.
6. Only the last EVD-R remote pickup requires the 10K Ohm, 1% end of line resistors. Remove the factory installed end of line resistors from all other EVD-R's and the EVD-M.
7. Connections to dry contacts from any UL listed safe contact. Last EVD-R is the preferred unit for connections to the safe contact. However, **all** EVD-R remote pickups accept safe contact wiring. Additional safe contacts can be wired into other EVD-R remote pickups, the EVD-M or a UL listed tampered junction box. If the safe contact is wired into the EVD-M, use the alternate cable clamp. (Potter #5280105)
8. The EVD-M must be connected to a UL listed control unit or power supply capable of providing nominal 12 VDC and standby power. 72 hours of standby power is required for bank vault alarms. 4 hours of standby power is required for mercantile alarms.
9. Connections to remote test annunciator or RTA and/or connection of dry contacts from any UL listed central station test unit. Refer to Figure 5 for detailed information on annunciator and remote test interconnections.
10. Terminals 1-12 on EVD-R are power limited.
11. Terminals 1-15 on EVD-M are power limited

Table 1. RECOMMENDED WIRE TYPES

Control Unit Connections	Remote Pickup Connections	Remote Test/ Annunciator Connections
Potter #5210408 Required for UL Safe Complete installations	Belden 8761 or Alpha 2401C	Belden 8444 or Alpha 1174C
4 Wire Hookup Belden 9512 General Cable C0762		
6 Wire Hookup Belden 9513 General Cable C0763		

**RECOMMENDED CONTROL PANEL WIRING AND
REMOTE TEST AND ANNUNCIATOR CONNECTIONS**

Figure 5a.

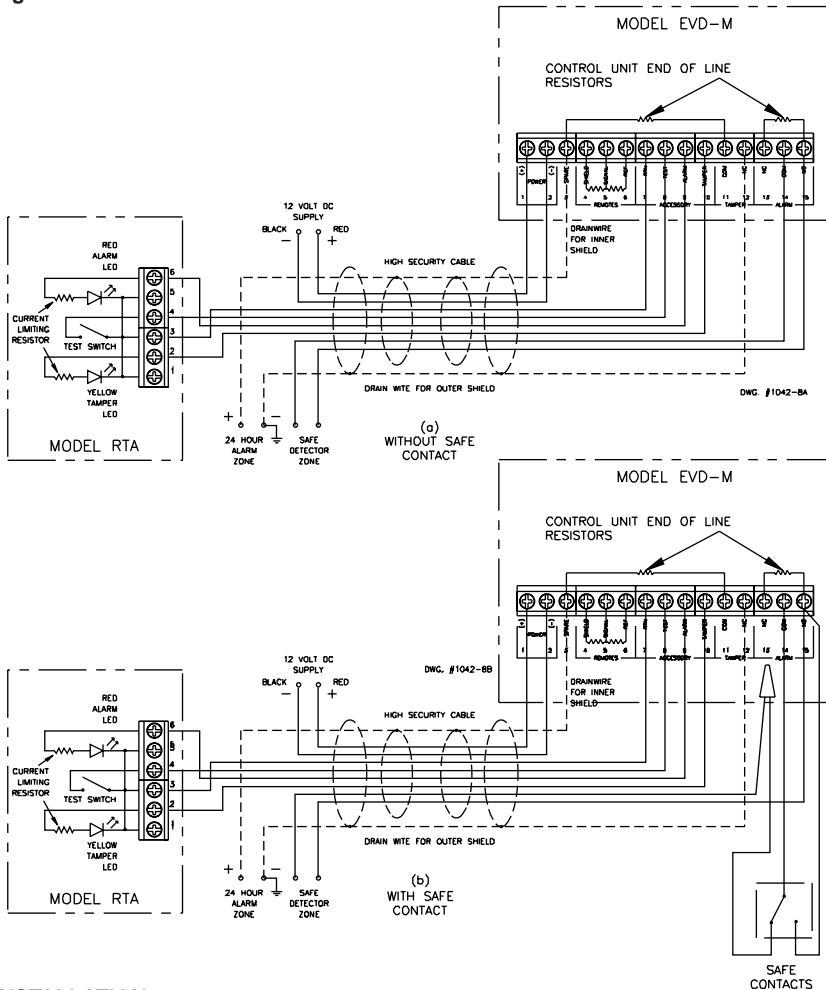

INSTALLATION

The EVD-2 System must be installed in accordance with all applicable local codes.

1. Mount EVD-M controller and any EVD-R remote pickups and wire according to Figures 4 and 5a. Remove end of line resistors from the EVD-M and all EVD-R's except the last EVD-R in the remote pickup network. If no remote pickups are installed do **not** remove the end of line resistors on the EVD-M.
2. Refer to Figure 5a for connection of a remote test annunciator, RTA, and/or a UL listed central station test unit, if applicable.
3. Refer to Figure 4 for the connection of UL listed dry contacts, if applicable.
4. Verify proper installation of the end of line resistors. Refer to Figures 2b and 4 for systems with remote pickups.
5. Wire control unit connections and apply 12 VDC to the EVD-2 system. Refer to Figure 5a.
6. See Figure 5b & 5c for 4 or 6 wire installation wiring.
7. High Security "B" cable and connectors to 24 hr alarm zone as shown are UL requirements for UL safe complete installation

RECOMMENDED CONTROL PANEL WIRING WITH SAFE DETECTOR ZONE AND 24 HOUR ALARM ZONE
 (High security B cable and connections to 24 hr zone as shown are required for UL safe compatible installations)

Figure 5b

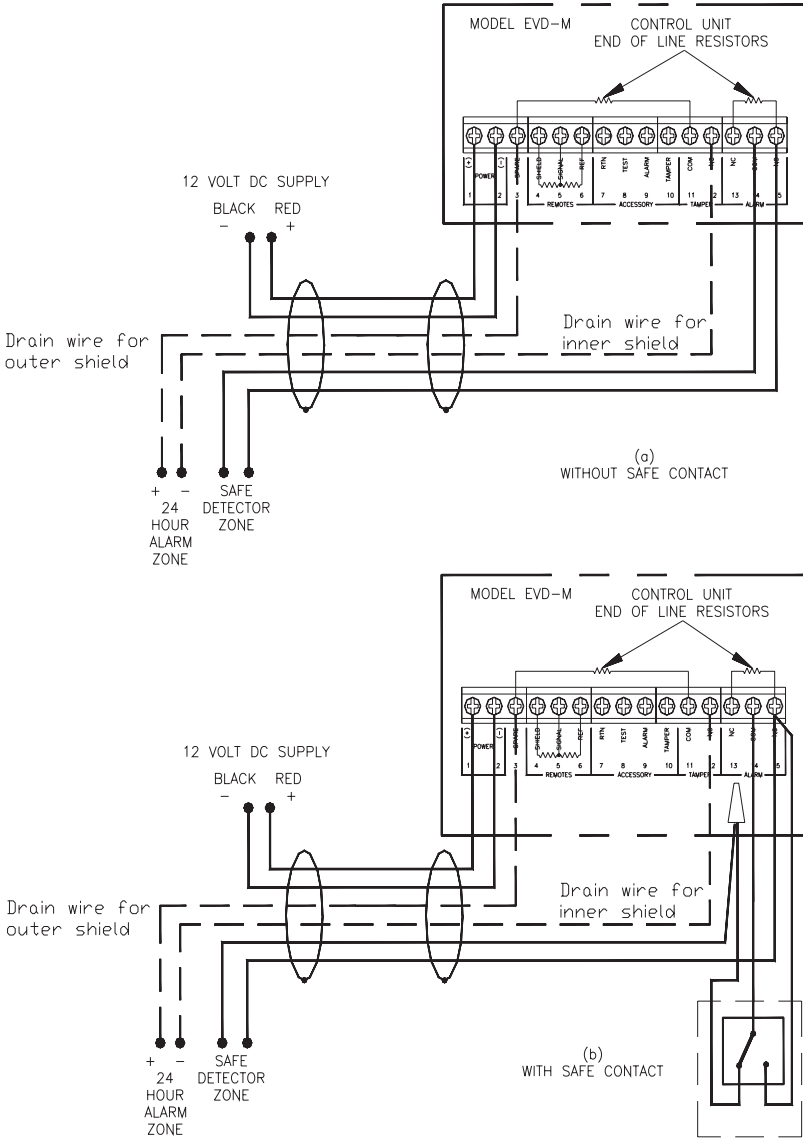

DWG. #EVD1

RECOMMENDED CONTROL PANEL WIRING WITH SAFE DETECTOR ZONE ONLY (4 Conductor Shielded Cable Required)

Figure 5c

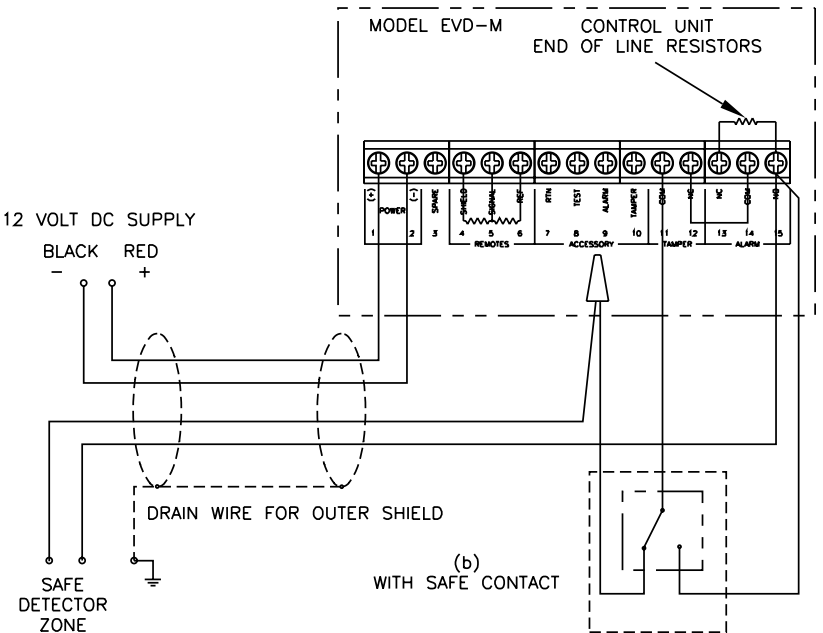
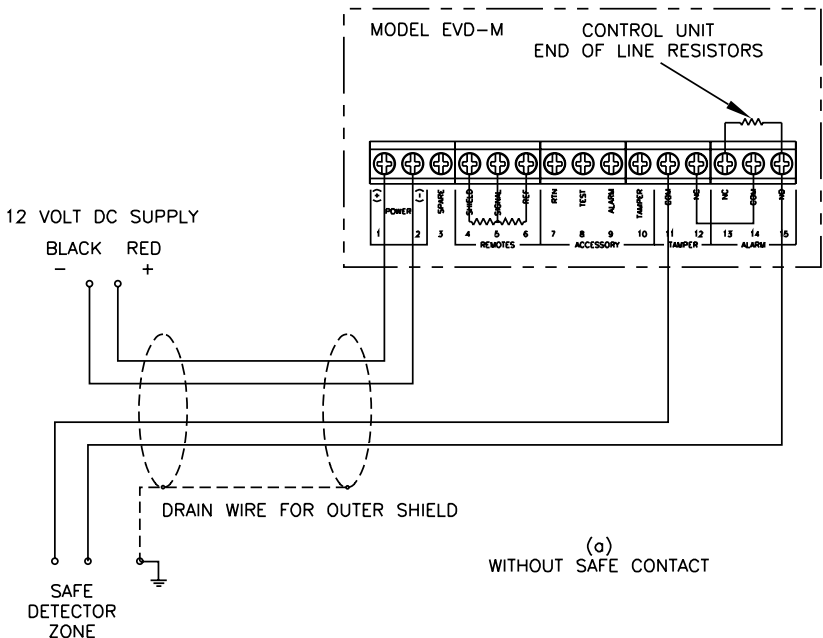

DWG. #EVD2

SENSITIVITY ADJUSTMENTS

1. Adjust the EVD-M's internal pickup sensitivity control, **RV1**, to 1/2 scale (12 o'clock position). Refer to Figure 1 for adjustment location.
2. If remote pickups are installed, adjust the EVD-M's remote pickup network sensitivity control, **RV2**, to the minimum setting listed in Table 2. If no EVD-R's are installed, adjust **RV2** to the minimum setting, fully counter-clockwise. Refer to Figure 1 for adjustment location.

Table 2.

Number of Remote Pickups	1	2	3	4	5	6	7	8	9	10	11	12	13	14	15
Minimum Remote Network Sensitivity Setting	0	0	0	1/4	1/4	1/4	1/4	1/4	1/2	1/2	1/2	1/2	1/2	3/4	3/4

3. Adjust accumulator rotary switch, **S1**, to desired setting. A setting of zero disables the accumulator function. Refer to Figure 1 for adjustment location.
4. Perform simulated attack tests on all accessible surfaces that are protected by the EVD-M and EVD-R's. Strike the protected surfaces using a plastic mallet or the plastic handle of a large screwdriver. An alarm condition (as indicated by the status LED turning RED) must occur. Lightly scrape the blade of a screwdriver next to the EVD-M and each EVD-R. After 15 seconds of **continuous** scraping, an alarm condition (as indicated by the status LED turning RED) must occur. **Be sure the scraping generates a test point voltage greater than the minimum constant noise level shown in Table 3.** Adjust sensitivity settings to the **minimum** needed to achieve desired level of response.

NOTE: Extreme care should be exercised so that the protected surfaces are not marred or damaged while performing simulated attack tests.

A voltmeter can be connected to the analog test point and pin 2 of the field wiring terminal block to aid the installer in adjusting the sensitivity controls. Refer to Figure 1 for analog test point location.

Table 3.

ANALOG TEST POINT LEVELS

Signal Description	Analog Test Point Level
Maximum Ambient Noise Level	0.20 VDC
Minimum <u>Constant</u> Noise for Alarm (except Drilling) (min. 15 sec. duration)	0.25 VDC
Minimum <u>Single</u> Noise for Alarm (Accumulator On)	0.70 VDC
Minimum <u>Single</u> Noise for Alarm (Accumulator Off)	1.25 VDC

5. With the system operating in a non-alarm state, verify the operation of all tampers. A tamper condition is indicated by the status LED turning AMBER. **If the system is in alarm when a tamper condition occurs, the status LED will remain RED, identifying the alarm condition. The tamper alarm remote annunciator and the tamper alarm contact always identify a tamper condition.**

TESTING

Applying a magnet to the side of the EVD-M controller, (see Figure 1), actuates a magnetic switch and generates a test signal. Similarly, applying a magnet to the side of an EVD-R remote pickup, (see Figure 3), actuates a magnetic switch and causes the EVD-R to transmit a test signal to the EVD-M controller. In both cases, the EVD-M: detects these alarm conditions, activates the alarm contacts, activates the alarm remote annunciator, and illuminates the status LED in RED.

NOTE: Most ordinary door contact magnets will activate the test feature on the EVD-M and the EVD-R.

System operation can also be verified from a remote location by use of an optional RTA and/or a UL listed central station test unit. Operating a normally open test switch generates a test signal which causes the EVD-M to signal an alarm condition.

NOTE: Always test unit prior to placing unit into service. Unit must be tested at least once a year.

SAFE CONSTRUCTION REQUIREMENTS

Table 4. Maximum Linear Distances from Detector to Any Point on the Protected Surface

Safe Construction	Maximum Linear Distance from Detector to Any Point	Local Pickup Minimum Sensitivity setting, RV1	Remote Pickup Minimum Sensitivity Setting, RV2
Steel Safes Body: Minimum 1/4" Door: Minimum 1/2"	96 inches	Fully Counterclockwise	Refer to Table 2
Composite Safes Body: Minimum 16 Gauge Steel over 3" Composite Material Door: Minimum 1/4" Steel over 3" Composite Material	110 inches	Fully Counterclockwise	Refer to Table 2

RECOMMENDED DETECTOR LOCATIONS

Single Detector Applications

All safe applications must have at least an EVD-M or an EVD-R on the body of the safe. When only one detector is required on a safe, mount the detector on the exterior of the safe on the door hinge side, near the front edge and centered within the height of the safe. (Ideally, mount the detector's sensor center point 2 inches in from the front edge of the safe on the centerline of the safe's height, refer to Figure 11). Figure 6. shows the recommended detector location of a safe application requiring one detector. **Safes with double doors require a minimum of two detectors, even if the dimensions of the safe conform to the requirements for the use of a single detector.**

Figure 6.

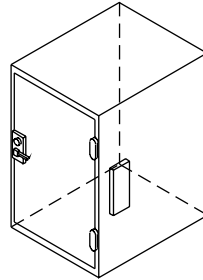

Two-Detector Applications

When two detectors are required on a safe, mount the first detector as recommended for a single detector installation. Mount the second detector on the opposite side of the safe, at the same height and with the same front edge offset as the first detector. **Safes with double doors that conform to the dimensional requirements for the use of one or two detectors should be protected in this fashion.** Figure 7. shows the recommended detector locations of a safe application requiring two detectors. Figure 8. shows the recommended detector location(s) of a safe application with double doors.

Figure 7.

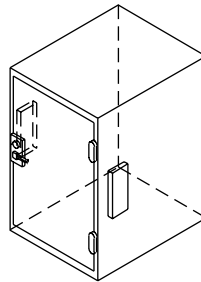
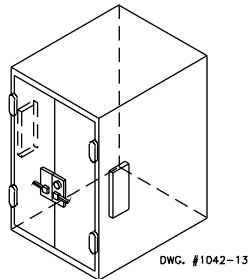

Figure 8.



Multiple Detector Applications

When more than two detectors are required on a safe, mount the first two detectors as recommended for a two-detector application. Mount the remaining detectors on the remaining surfaces, centered and spaced evenly to ensure complete detector coverage. Alternately, mount a detector centrally on the safe door and the remaining detectors centrally on the remaining surfaces, evenly spaced.

NOTE: If any recommended detector location is not physically accessible, contact Potter's technical support for assistance.

DETERMINING THE NUMBER OF DETECTORS FOR A SAFE APPLICATION

Refer to column one in Table 4 for the type of the safe in the application. In column two find the maximum linear distance from a detector to any point on the protected surface. This distance is the **detector range**. Next, refer to column one, (for steel safes), or column two, (for composite safes), in Table 5. Find the range of distances based upon the detector range that corresponds to the safe in the application. Using the row of this range of distances, determine the number of detectors from column three, (if safe has a single door), or from column four, (if safe has double doors). In some single detector applications, the EVD-2 system may be used to protect multiple safes via a combination of an EVD-M and multiple EVD-R remote pickups. For applications with a larger distance than that shown in Table 5, consult Potter's technical support for assistance.

Table 5.

Maximum Linear Distance from Detector to Any Point on Protected Surfaces of Steel Safes*	Maximum Linear Distance from Detector to Any Point on Protected Surfaces of Composite Safes**	Number of Detectors Required for Complete Coverage of Single Door Safes	Number of Detectors Required for Complete Coverage of Double Door Safes
$D \leq 96"$	$D \leq 110"$	1	2
$96" < D \leq 192"$	$110" < D \leq 220"$	2	2
$192" < D \leq 288"$	$220" < D \leq 330"$	3	3
$288" < D \leq 384"$	$330" < D \leq 440"$	4	4
$384" < D \leq 480"$	$440" < D \leq 550"$	5	5

NOTE: D=Maximum Linear Distance

*Steel Safe Construction:

Body: Minimum 1/4" Steel

Door: Minimum 1/2" Steel

**Composite Safe Construction:

Body: Minimum 16 Gauge Steel over 3" Composite Material

Door: Minimum 1/4" Steel over 3" Composite Material

DETERMINING THE MAXIMUM LINEAR DISTANCE ON A SAFE

A rule of thumb for estimating the maximum linear distance from the recommended detector location to any point on the protected surface is:

Example: $h = 62''$ $w = 55''$ $d = 29''$

- | | | |
|------------|-------------------------------|---------------------------------------------------|
| 1. Compute | $X1 = h + w$ | 1. $X1 = 62'' + 55''$ ($X1 = 117''$) |
| 2. Compute | $X2 = 2d + w$ | 2. $X2 = (2 \times 29'') + 55''$ ($X2 = 113''$) |
| 3. Find | $X = \text{minimum} (X1, X2)$ | 3. $X = 113''$ |
| 4. Compute | $J = w + d$ | 4. $J = 55'' + 29''$ ($J = 84''$) |
| 5. Find | $D = \text{maximum} (X, J)$ | 5. $D = 113''$ |

Where: h = Safe Height
 w = Safe Width
 d = Safe Depth
 D = Maximum Linear Distance

This rule of thumb is valid for **most** available safe sizes. However, if any one dimension is very large or very small when compared to the other two dimensions, the safe may not follow this rule. In those cases, contact Potter's technical support for assistance. Table 6 lists some common safe dimensions and their maximum linear distances when detectors are installed in recommended locations.

Table 6. Typical Safe Exterior Dimensions and Maximum Linear Distances

Height (Inches)	Width (Inches)	Depth (Inches)	Volume (cu. ft.)	Maximum Linear Distance (Inches)
25.00	21.00	21.00	6.38	46.00
32.00	25.00	25.00	11.57	57.00
42.00	31.00	29.00	21.85	73.00
52.00	31.00	29.00	27.05	83.00
62.00	31.00	29.00	32.26	89.00
62.00	55.00	29.00	57.23	113.00
64.00	31.00	29.00	33.30	89.00
72.00	35.00	29.00	42.29	93.00
79.00	43.00	33.00	64.87	109.00

TYPICAL UL COMPLETE SAFE INSTALLATIONS

1. Install in accordance with Underwriter Laboratories' standard UL 681.
2. Install EVD-M and EVD-R detectors in recommended locations at recommended spacings.
3. Install UL listed, high security contacts on the exterior of the safe or UL listed, ordinary use contacts on the inside of the safe.
4. Wire detectors and safe door contacts as shown in Figures 4 and 5a.
5. Listed power supply or control unit must provide at least 4 hours of standby power for mercantile alarms and 72 hours of standby power for bank vault alarms.

TYPICAL UL COMPLETE VAULT INSTALLATIONS

1. Install in accordance with Underwriter Laboratories' standard UL 681.
2. Install EVD-M and EVD-R detectors on interior walls, ceilings, and floors, spaced as shown in figure 9. Refer to Table 7 for maximum spacing on various materials.
3. A detector must be installed on the vault door if the net steel thickness is less than 1 1/2 inches.
4. Wire detectors and door contacts as shown in Figures 4 and 5a.
5. Listed power supply or control unit must provide at least 4 hours of standby power for mercantile alarms and 72 hours of standby power for bank vault alarms.

EVD-2 WALL PROTECTION

Figure 9 shows the rectangular areas of 100% coverage when detectors are installed adjacent to one another. The detector spacing is the sensor center point distance between adjacent detectors. The detector spacing is the same as the width of the rectangular area of 100% coverage. Table 7 lists the dimensions of the rectangular areas of 100% coverage on continuous surfaces for several materials and sensitivity settings. When a surface extends around a corner via a solid connection, detector coverage extends into that surface, but the coverage is reduced to 3/4 of the remaining detector range. All joints, cracks, and corners dampen structure borne vibrations. Vibration transfer across these imperfections must be tested to ensure complete coverage within the detector's range. Modular constructions require one detector per panel and must be constructed of the materials listed in Tables 4 and 7.

Figure 9.

WALL PROTECTION DIAGRAM

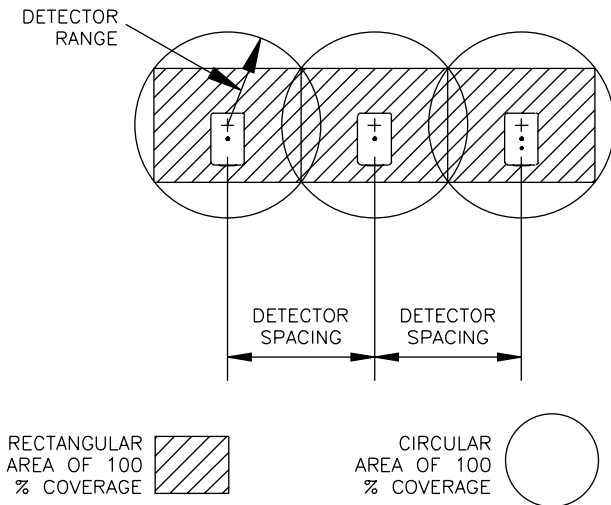

DWG. #1042-15

Table 7. RECOMMENDED MAXIMUM EVD-M/EVD-R SPACING FOR WALL PROTECTION

Material	Sensitivity Setting	Detector Range	Rectangular Area of 100% Coverage				
Steel Plate at Least 1/4" Thick	Minimum	8.0'	11.3 x 11.3'	8' x 13.9'	10' x 12.5'	15' x 5.6'	-
	Half	15.0'	21.2' x 21.2'	8' x 28.9'	10' x 28.3'	15' x 26'	20' x 22.4'
	Maximum	20.0'	28.3' x 28.3'	8' x 39.2'	10' x 38.7'	15' x 37.1'	20' x 34.6'
Monolithic Concrete at Least 6" Thick	Minimum	16.0'	22.6' x 22.6'	8' x 31.0'	10' x 30.4'	15' x 28.3'	20' x 25.0'
Concrete Block at Least 6" Thick	Minimum	16.0'	22.6' x 22.6'	8' x 31.0'	10' x 30.4'	15' x 28.3'	20' x 25.0'

Figure 10.

DIMENSIONS

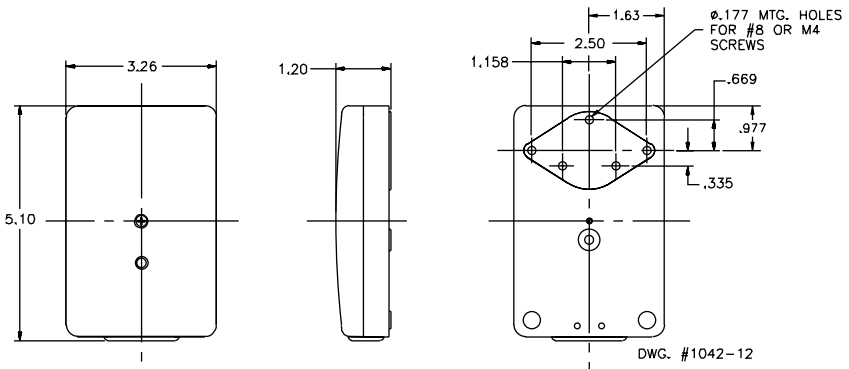

ALL DIMENSIONS IN INCHES

Figure 11.

EVD-M OR EVD-R MOUNTING TEMPLATE

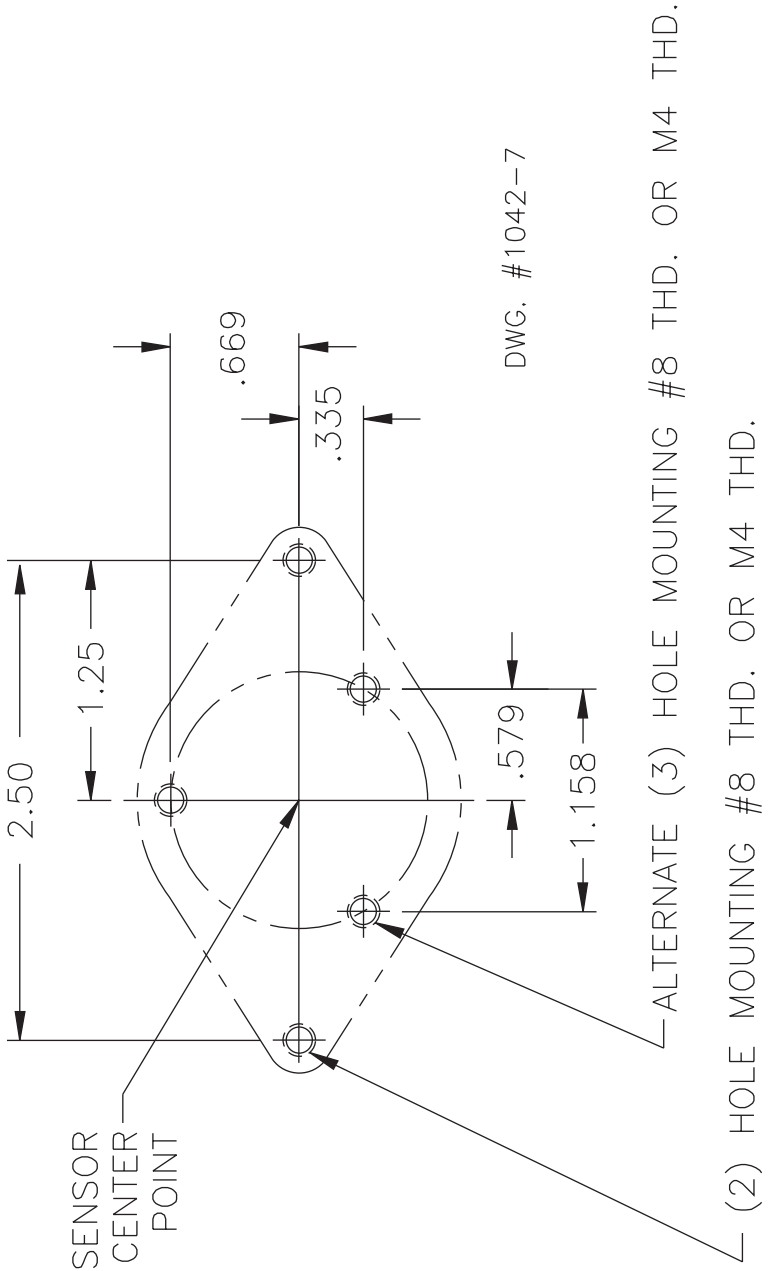

ALL DIMENSIONS IN INCHES